

**FUNDAMENTAL PROBLEMS**

F8-1. Draw the deflected shape of each beam.

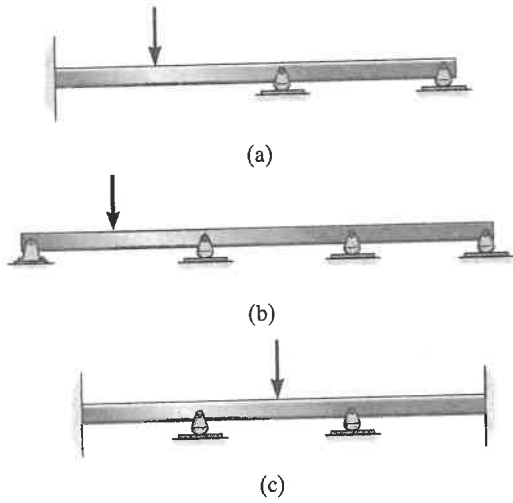

F8-1

F8-2. Draw the deflected shape of each beam.

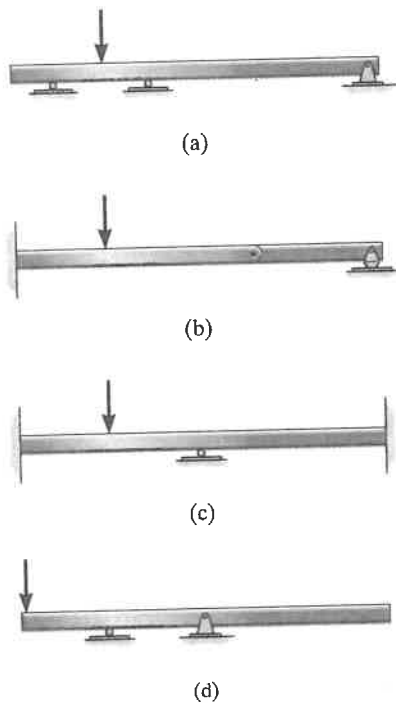

F8-2

F8-3. Draw the deflected shape of each frame.

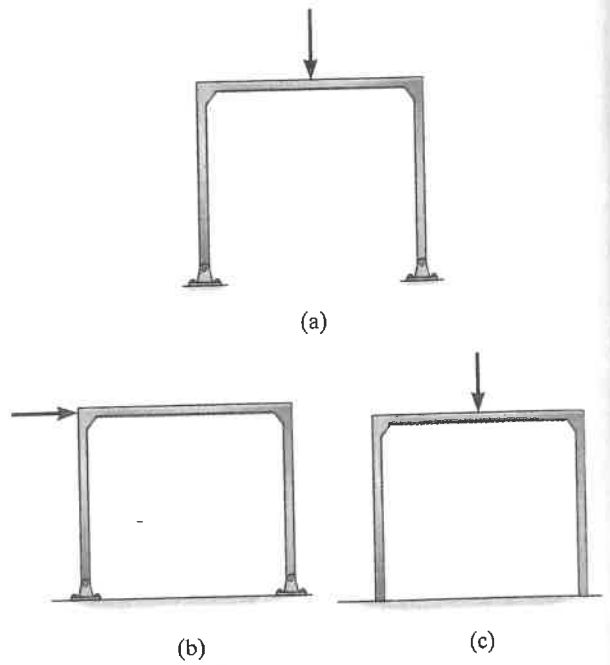

F8-3

F8-4. Draw the deflected shape of each frame.

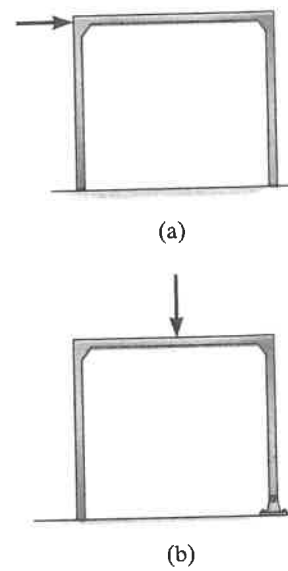

F8-4

**F8-5.** Draw the deflected shape of each frame.



(a)

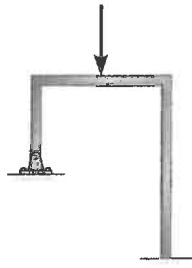

(b)

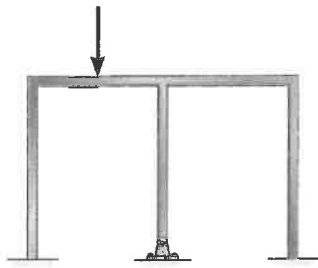

(c)

**F8-5**

**F8-6.** Determine the equation of the elastic curve for the beam using the  $x$  coordinate that is valid for  $0 < x < L$ .  $EI$  is constant.

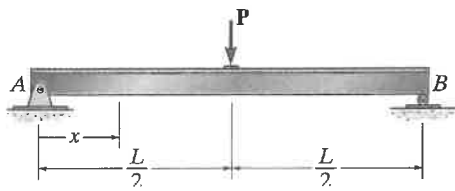

**F8-6**

**F8-7.** Determine the equation of the elastic curve for the beam using the  $x$  coordinate that is valid for  $0 < x < L$ .  $EI$  is constant.

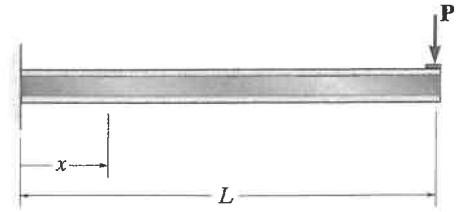

**F8-7**

**F8-8.** Determine the equation of the elastic curve for the beam using the  $x$  coordinate that is valid for  $0 < x < L$ .  $EI$  is constant.

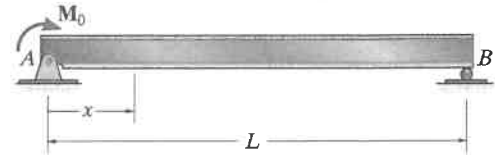

**F8-8**

**F8-9.** Determine the equation of the elastic curve for the beam using the  $x$  coordinate that is valid for  $0 < x < L$ .  $EI$  is constant.

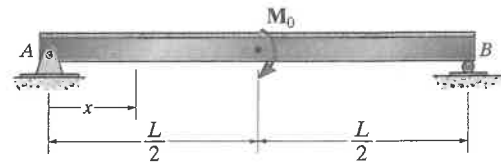

**F8-9**

## PROBLEMS

## Sec. 8.1–8.3

8-1. Determine the equations of the elastic curve for the beam using the  $x_1$  and  $x_2$  coordinates. Specify the slope at  $A$  and the maximum deflection.  $EI$  is constant.

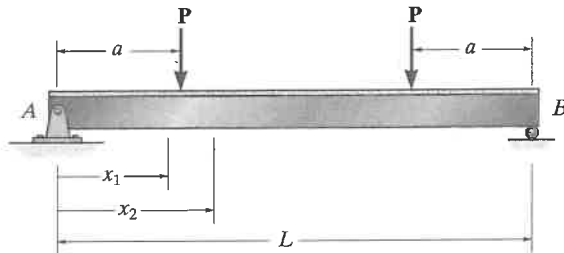

Prob. 8-1

8-2. The bar is supported by a roller constraint at  $B$ , which allows vertical displacement but resists axial load and moment. If the bar is subjected to the loading shown, determine the slope at  $A$  and the deflection at  $C$ .  $EI$  is constant.

8-3. Determine the deflection at  $B$  of the bar in Prob. 8-2.

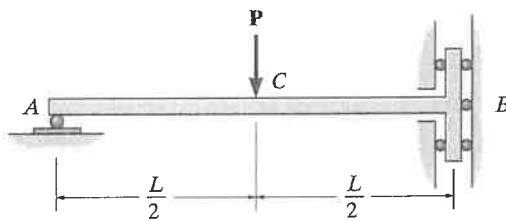

Probs. 8-2/3

\*8-4. Determine the equations of the elastic curve using the coordinates  $x_1$  and  $x_2$  and specify the slope and deflection at  $B$ .  $EI$  is constant.

8-5. Determine the equations of the elastic curve using the coordinates  $x_1$  and  $x_3$  and specify the slope and deflection at point  $B$ .  $EI$  is constant.

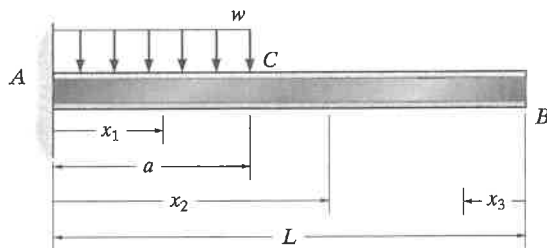

Probs. 8-4/5

8-6. Determine the equations of the elastic curve for the beam using the  $x$  coordinate. Specify the slope at  $A$  and the maximum deflection of the beam.  $EI$  is constant.

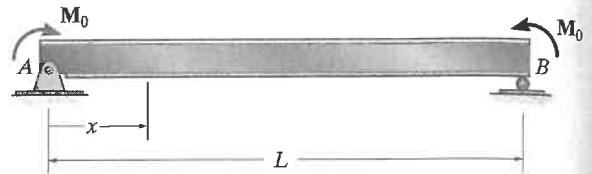

Prob. 8-6

8-7. Determine the equations of the elastic curve using the  $x_1$  and  $x_2$  coordinates.  $EI$  is constant.

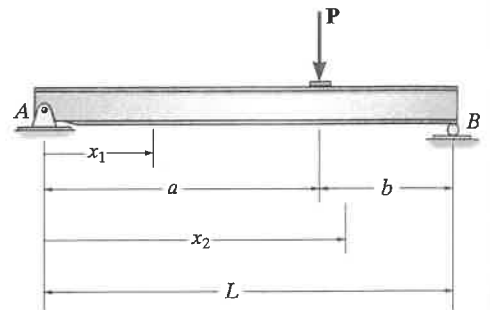

Prob. 8-7

\*8-8. Determine the equations of the elastic curve using the coordinates  $x_1$  and  $x_2$  and specify the slope at  $C$  and displacement at  $B$ .  $EI$  is constant.

8-9. Determine the equations of the elastic curve using the coordinates  $x_1$  and  $x_3$  and specify the slope at  $B$  and deflection at  $C$ .  $EI$  is constant.

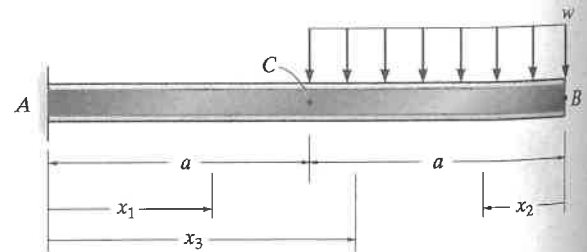

Probs. 8-8/9