

PROBLEMS

1-1. The floor of a heavy storage warehouse building is made of 6-in.-thick stone concrete. If the floor is a slab having a length of 15 ft and width of 10 ft, determine the resultant force caused by the dead load and the live load.

1-2. The wall is 12-ft high and consists of 2×4 studs. On each side is acoustical fiberboard and 4-in. clay brick. Determine the average load in lb/ft of length of wall that the wall exerts on the floor.

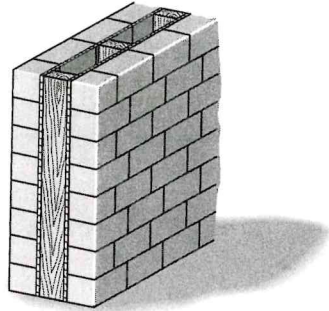

Prob. 1-2

1-3. A building wall consists of 12-in. clay brick and $\frac{1}{2}$ -in. fiberboard on one side. If the wall is 10 ft high, determine the load in pounds per foot that it exerts on the floor.

*1-4. The "New Jersey" barrier is commonly used during highway construction. Determine its weight per foot of length if it is made from plain stone concrete.

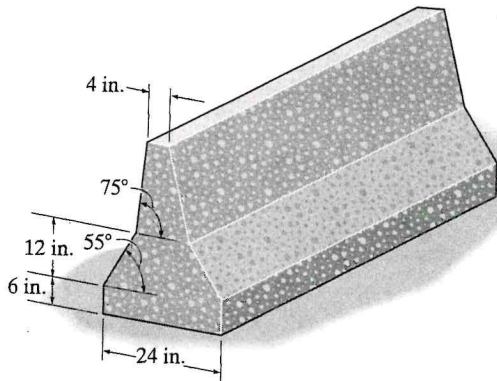

Prob. 1-4

1-5. The precast floor beam is made from concrete having a specific weight of 150 lb/ft^3 . If it is to be used for a floor in an office of an office building, calculate its dead and live loadings per foot length of beam.

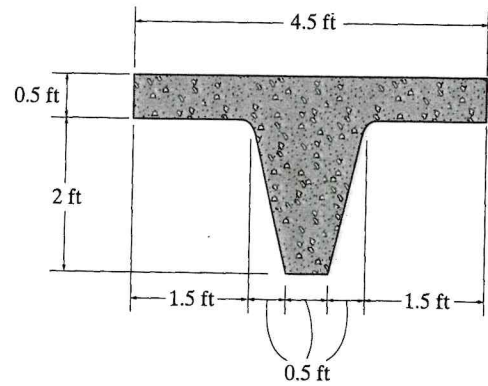

Prob. 1-5

1-6. The floor of a light storage warehouse is made of 150-mm-thick lightweight plain concrete. If the floor is a slab having a length of 7 m and width of 3 m, determine the resultant force caused by the dead load and the live load.

*1-7. The pre-cast T-beam has the cross-section shown. Determine its weight per foot of length if it is made from reinforced stone concrete and eight $\frac{3}{4}$ -in. cold-formed steel reinforcing rods.

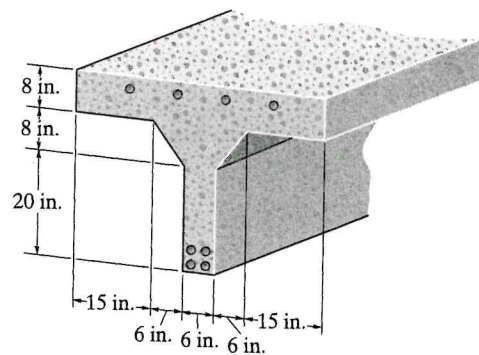

Prob. 1-7

- 1 *1-8. The building wall consists of 8-in. clay brick. In the interior, the wall is made from 2×4 wood studs, plastered on one side. If the wall is 10 ft high, determine the load in pounds per foot of length of wall that the wall exerts on the floor.

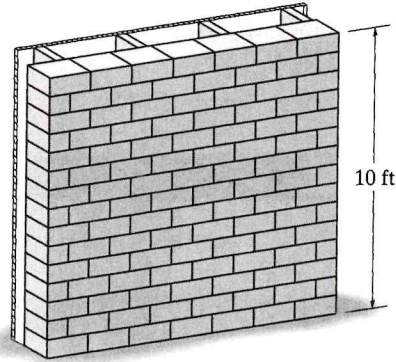

Prob. 1-8

- 1-9. A building wall consists of exterior stud walls with brick veneer and 13 mm fiberboard on one side. If the wall is 4 m high, determine the load in kN/m that it exerts on the floor.

- 1-10. The interior wall of a building is made from 2×4 wood studs, plastered on two sides. If the wall is 12 ft high, determine the load in lb/ft of length of wall that it exerts on the floor.

- 1-11. The beam supports the roof made from asphalt shingles and wood sheathing boards. If the boards have a thickness of $1\frac{1}{2}$ in. and a specific weight of 50 lb/ft^3 , and the roof's angle of slope is 30° , determine the dead load of the roofing—per square foot—that is supported in the x and y directions by the purlins.

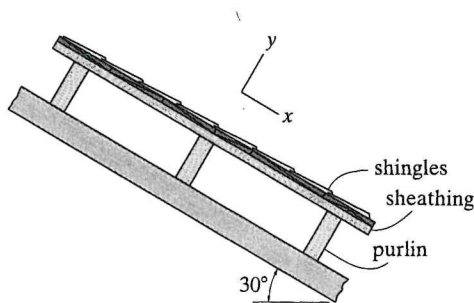

Prob. 1-11

- *1-12. A three-story hotel has interior columns that are spaced 20 ft apart in two perpendicular directions. If the loading on the flat roof is estimated to be 30 lb/ft^2 , determine the live load supported by a typical interior column at (a) the ground-floor level, and (b) the second-floor level.

- 1-13. A hospital is to be built on open flat terrain in central Texas. If the building is 9.1 meters high, determine the internal pressure within the building if it is fully enclosed. Also, what is the external wind pressure acting on the side walls of the building? Each wall of the building is 25 meters long.

- 1-14. The office building has interior columns spaced 5 m apart in perpendicular directions. Determine the reduced live load supported by a typical interior column located on the first floor under the offices.



Prob. 1-14

- 1-15. A hospital located in Chicago, Illinois, has a flat roof, where the ground snow load is 25 lb/ft^2 . Determine the design snow load on the roof of the hospital.

***1-16.** Wind blows on the side of a fully enclosed hospital located on open flat terrain in Arizona. Determine the external pressure acting over the windward wall, which has a height of 30 ft. The roof is flat.



Prob. 1-16

1-17. Wind blows on the side of the fully enclosed hospital located on open flat terrain in Arizona. Determine the external pressure acting on the leeward wall, which has a length of 200 ft and a height of 30 ft.



Prob. 1-17

1-18. Determine the resultant force acting on the face of the sign if $q_h = 3.70$ kPa. The sign has a width of 12 m and a height of 3 m as indicated.

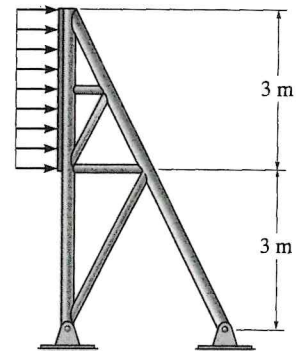

Prob. 1-18

1-19. The light metal storage building is on open flat terrain in central Oklahoma. If the side wall of the building is 14 ft high, what are the two values of the external wind pressure acting on this wall when the wind blows on the back of the building? The roof is essentially flat and the building is fully enclosed.



Prob. 1-19

- 1 *1-20. The horse stall has a flat roof with a slope of 80 mm/m. It is located in an open field where the ground snow load is 1.20 kN/m^2 . Determine the snow load that is required to design the roof of the stall.

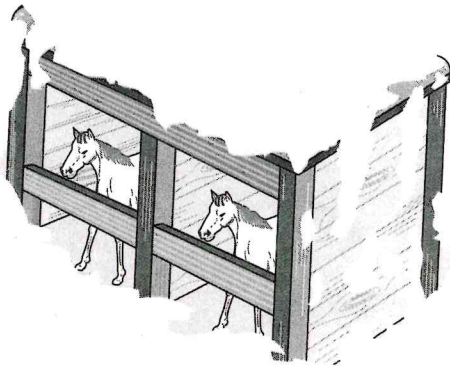

Prob. 1-20

- 1-21. The horse stall has a flat roof with a slope of 80 mm/m. It is located in an open field where the ground snow load is 0.72 kN/m^2 . Determine the snow load that is required to design the roof of the stall.

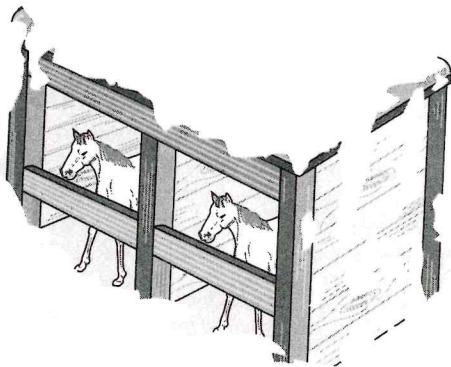

Prob. 1-21

- 1-22. A hospital located in central Illinois has a flat roof. Determine the snow load in kN/m^2 that is required to design the roof.

- 1-23. The school building has a flat roof. It is located in an open area where the ground snow load is 0.68 kN/m^2 . Determine the snow load that is required to design the roof.



Prob. 1-23

- *1-24. Wind blows on the side of the fully enclosed agriculture building located on open flat terrain in Oklahoma. Determine the external pressure acting over the windward wall, the leeward wall, and the side walls. Also, what is the internal pressure in the building which acts on the walls? Use linear interpolation to determine q_h .

- 1-25. Wind blows on the side of the fully enclosed agriculture building located on open flat terrain in Oklahoma. Determine the external pressure acting on the roof. Also, what is the internal pressure in the building which acts on the roof? Use linear interpolation to determine q_h and C_p in Fig. 1-13.

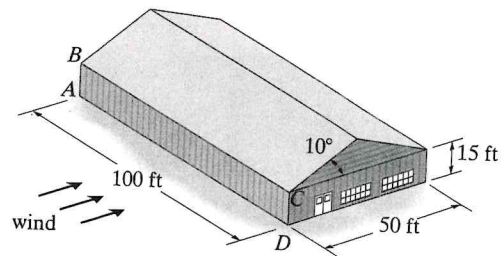

Probs. 1-24/25